



*Communications  
& Power Industries*

**M7-13**

**FABRICATION STANDARDS**

**COMMUNICATIONS & POWER INDUSTRIES LLC  
MICROWAVE POWER PRODUCTS DIVISION**

Revision: BC  
ECO: MPP622853  
March 5, 2021

**TABLE OF CONTENTS**

<b>PREFACE</b> .....	1
<b>REFERENCES</b> .....	1
<b>DEFINITIONS</b> .....	1
1.0 RAW MATERIALS .....	2
2.0 STANDARDS FOR RAW-MATERIAL MACHINING ALLOWANCES .....	3
2.1 Minimums .....	3
2.2 Calculation of Raw-Material Dimensions .....	3
2.3 Tubing .....	5
3.0 CERTIFICATION .....	5
3.1 Delivery or Storage of Certifications .....	5
3.2 Requirements on All Certifications .....	6
3.3 Certification Types .....	6
4.0 PACKAGING AND LABELING .....	7
4.1 Parts Protection in Packing .....	7
4.2 Transportation .....	8
4.3 Package Labeling .....	9
4.4 Packaging and Labeling of Beryllium Containing Parts and Materials .....	9
5.0 GEOMETRIC DIMENSIONING AND TOLERANCING SYSTEM .....	10
5.1 Unspecified Tolerance .....	10
5.2 Unspecified Finish .....	10
5.3 Unspecified Flatness .....	10
5.4 Unspecified Cylindricity .....	11
5.5 Unspecified Perpendicularity .....	11
5.6 Unspecified Parallelism .....	11
5.7 Unspecified Concentricity .....	11
5.8 Unspecified Position .....	12
5.9 Unspecified Circularity .....	12
5.10 Unspecified Countersinks .....	12
6.0 TOOLING .....	12
7.0 CLEANING, PLATING, AND COATING OF SURFACES .....	12
8.0 BURRS .....	13
8.1 Definition .....	13

**MANUFACTURING SPECIFICATION**

8.2	Types .....	13
8.3	Height .....	13
8.4	Removal.....	13
8.5	Edges .....	14
8.6	Corners .....	14
8.7	Sheet Metal.....	15
9.0	THREADS .....	15
9.1	Internal Threads .....	15
9.2	Threaded Holes .....	15
9.3	Threaded Parts .....	16
9.4	Full-Form Threads .....	16
9.5	Unspecified Thread Class of Fit .....	16
10.0	SHEET-METAL PRODUCTS FABRICATION REQUIREMENTS .....	16
10.1	Sheet Metal.....	16
10.2	Features and Surfaces .....	16
10.3	Machined Features .....	16
10.4	Circular Runout.....	17
10.5	Washer-Type Punching .....	17
10.6	Flatness .....	17
10.7	Parallelism and Perpendicularity .....	18
10.8	Edges and Corners.....	18
10.9	Stock Thickness after Forming .....	18
10.10	Breakaway .....	18
10.11	Burrs .....	19
10.12	Burr Symbols and Drawing Callouts .....	19
11.0	CASTING AND FORGING REQUIREMENTS .....	19
11.1	Position .....	20
11.2	Flatness .....	20
11.3	Cleanup .....	21
11.4	Mismatch .....	21
11.5	Draft.....	21
11.6	Repair .....	21
12.0	EDM FABRICATION REQUIREMENTS .....	21
	<b>APPENDIX: Geometric Symbology .....</b>	<b>22</b>

**ATTENTION**

UNLESS OTHERWISE SPECIFIED ON THE PURCHASE ORDER(S) OR CPI INTERNAL SHOP WORK ORDER(S), CONFORMANCE TO ALL REQUIREMENTS OF THE DRAWING(S) AND SPECIFICATION(S) IS MANDATORY.

**PREFACE**

The object of the Fabrication Standards Specification M7-13 is to supplement the design information on CPI drawings for microwave Vacuum Electron Device (VED) assemblies and components. Suppliers and CPI manufacturing units shall be responsible for the implementation of these standards in the performance of work for CPI as outlined in CPI purchase orders and shop work orders.

This standard reflects the technical requirements for the Microwave Power Products Division (MPP) of Communications and Power Industries LLC.

The previous Section 6.0, "Coolants, Lubricants, and Solvents," which has been a part of past revisions, is now a separate, subordinate document (M7-179, "Approved Lubricants, Coolants, and Solvents") to facilitate subsequent revisions. All data therein are still considered flow-down requirements from M7-13.

**Failure to comply with the requirements contained in the Fabrication Standards may result in the rejection of the material produced. In the event of a conflict between the standards, the drawing, and/or the purchase order, the purchase order shall take precedence, the drawing next, and then the standards.**

All questions from Suppliers concerning the interpretation of the standards shall be directed to the CPI MPP Purchasing Department. Additional information or revisions shall be provided to Suppliers and all CPI departments engaged in fabrication of piece parts, subassemblies, and finished products.

**REFERENCES (Latest Revision)**

40 CFR, Part 82	Protection of Stratospheric Ozone
ASME Y14.5	Dimensions and Tolerancing
FED-STD-H28	Screw Thread Standards for Federal Services
CPI M7-35	Inventory Packaging
CPI M7-179	Approved Lubricants, Coolants, and Solvents
CPI P0-1	Approved Sources for Raw Materials and Processes (Including Sections 1, 2, 3, and 4)
CPI P0-3	Supplier Quality System Requirements
CPI P18-2	Clean Packaging of Supplier-Provided Parts

**DEFINITIONS**

CMM	Coordinate Measuring Machine
EDM	Electrical Discharge Machining
EPA	Environmental Protection Agency
MMC	Maximum Material Condition
Non-Vacuum Assembly	An assembly that is not within or part of the vacuum envelope
Non-Vacuum Part	A part that is not within or part of the vacuum envelope
OFE	Oxygen Free Electronic

**Revision Information**

Updated to add clarification on minimum raw material stock size in Section 2.2.

PO	Purchase Order
P-Spec	Purchasing Specification
RFS	Regardless of Feature Size
Vacuum Assembly	An assembly that is within or part of the vacuum envelope
Vacuum Part	A part that is within or part of the vacuum envelope
VED	Vacuum Electron Device (modern name for “microwave tube”)

## 1.0 RAW MATERIALS

The performance of VEDs is critically dependent upon the strict conformance of raw materials to specifications and to proper processing and cleanliness practices. CPI’s products are subjected to numerous high-temperature cycles during their assembly and processing and must still retain high-vacuum integrity, strength, and inherent thermal and magnetic properties. To this end, the Supplier shall be required to use **ONLY** the material specified on the drawing or on the PO to fabricate the required parts.

**NOTE**  
**USE OF UNAUTHORIZED MATERIAL IS NOT ALLOWED.**  
Violations shall result in removal from the Approved Supplier List and possible exposure to consequential damages.

Some of the raw materials used by CPI have directional properties resulting from segregation or inclusions that can seriously jeopardize the vacuum integrity of microwave VEDs. For example,

- Low-carbon steels have regions of high-carbon content.
- Stainless steels contain sulfide or oxide inclusions.
- Cupronickel occasionally exhibits slag inclusions.

During ingot reduction, these concentrations of impurities are “stretched out” in the rolling or drawing direction, forming “stringers” (i.e., in the plane of flat or sheet stock and on the axis for bar stock). CPI parts that are designed for vacuum applications will always prescribe a material orientation to ensure that a potential stringer leak path will run parallel to the vacuum wall instead of piercing it. Allowable forms are defined in the purchasing specification (P-Spec) and denoted in the materials block of individual drawings by a P-Spec suffix. The “Grain Symbol” (  ) may also be used in instances of critical orientation.

- Sourcing of raw materials shall be in strict accordance with CPI P0-1, “Approved Sources for Raw Materials and Processes.”
- All raw materials must be positively identified and directly traceable to the certifications that demonstrate the material’s conformance to stated requirements.
- Surplus material, including remnants, overage, and scrap, that cannot be traced directly to its certifications shall under no circumstances be used to fabricate parts for CPI.
- Alternate forms of raw materials (i.e., plate, bar, sheet, etc.) may not be substituted without written approval from CPI.
- It is unallowable to use welded tubing or to roll and weld flat stock unless specifically prescribed in the drawing or PO.
- It is unallowable to repair parts by welding, plugging, flame spraying, or other methods without written approval from CPI.

**2.0 STANDARDS FOR RAW-MATERIAL MACHINING ALLOWANCES**

This section prescribes machining allowances for raw materials to ensure the removal of surface defects and oxides. Material with no allowance has been demonstrated to have a useable surface as received.

**2.1 Minimums**

The allowances specified are minimums to be removed from each side. Where greater amounts must be removed, it is recommended that an equal amount be removed from both sides as permitted by available raw-material dimensions. If surface defects are still visible after removal of the machining allowance, the material should not be used at all.

**2.2 Calculation of Raw-Material Dimensions**

The minimum size of the raw material shall be determined as follows:

Determine the "Finished" dimension from the print and ADD the following amounts:

<b>For Chromium Copper/Chromium Zirconium Copper Alloys (All Forms Except Castings and Forgings)</b>		
<b>Under 0.250" Thick</b>	<b>0.251" to 1.000" Thick</b>	<b>Above 1.000" Thick</b>
0.020" from each surface	0.030" from each surface	0.060" from each surface

<b>For Chromium Copper/Chromium Zirconium Copper Alloys Castings and Forgings</b>		
<b>Under 0.250" Thick</b>	<b>0.251" to 1.000" Thick</b>	<b>Above 1.000" Thick</b>
0.020" from each surface	0.10" from each surface	0.50" from each surface

<b>For OFE Copper (Flat Plate and Rectangular Bar)</b>		
<b>Under 0.250" Thick</b>	<b>0.251" to 1.000" Thick</b>	<b>Above 1.000" Thick</b>
None	5% min from each surface	0.06" min from each surface

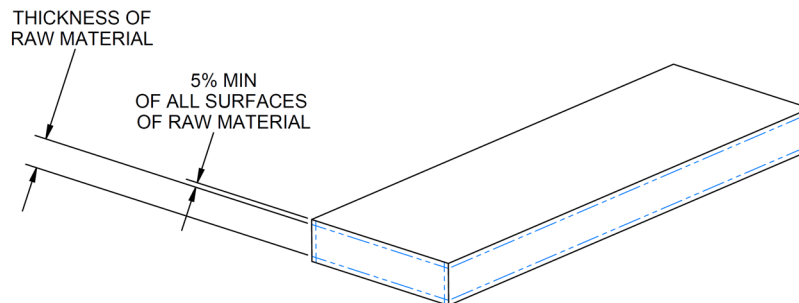

**FIGURE 1: For OFE Copper (Flat Plate and Rectangular Bar)**

<b>For OFE Copper (Round Bar or Rod)</b>		
<b>Under 0.250" Dia.</b>	<b>0.251" to 1.000" Dia.</b>	<b>Above 1.000" Dia.</b>
None	10% min to diameter	0.12" min to diameter

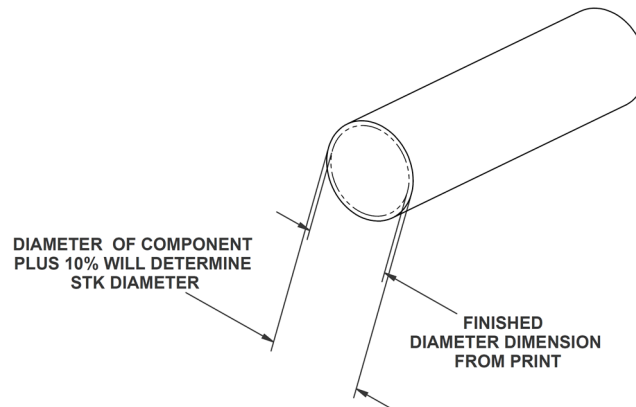

**FIGURE 2: For OFE Copper (Round Bar or Rod)**

<b>For OFE Copper Castings and Forgings</b>		
<b>Under 0.250" Thick</b>	<b>0.251" to 1.000" Thick</b>	<b>Above 1.000" Thick</b>
N/A	N/A	0.50" min from each surface

<b>For All Others (Flat Plate and Rectangular Bar)</b>		
<b>Under 0.250" Thick</b>	<b>0.251" to 1.000" Thick</b>	<b>Above 1.000" Thick</b>
None	2% min to each surface	0.020" min to each surface

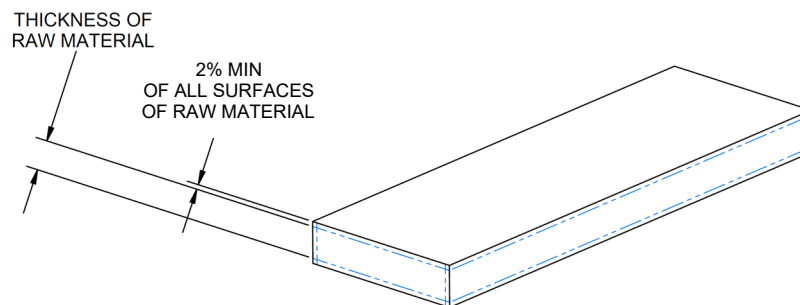

**FIGURE 3: For All Others (Flat Plate and Rectangular Bar)**

<b>For All Others (Round Bar or Rod)</b>		
<b>Under 0.250" Dia.</b>	<b>0.251" Dia. to 1.000" Dia.</b>	<b>Above 1.000" Dia.</b>
None	4% min to diameter	0.040" min to diameter

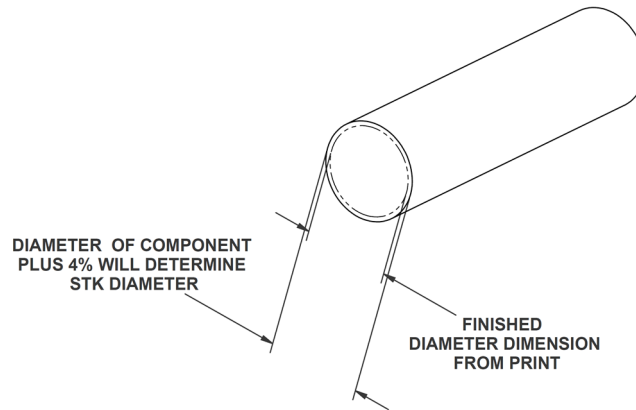

**FIGURE 4: For All Others (Round Bar or Rod)**

**2.3 Tubing**

The raw-material sizes for the OD of tubing shall be calculated in the same way as the round bar diameter.

The maximum ID of tubing shall be calculated by DEDUCTING the following amounts from the "Finished" dimension:

<b>Under 1.000" ID</b>	<b>Above 1.000" ID</b>
None	0.040" min

**3.0 CERTIFICATION**

This section defines the items requiring certification as specified by CPI and states the minimum information that must accompany the parts or assemblies.

**3.1 Delivery or Storage of Certifications**

This section defines the instances wherein the Supplier is to include the certification with the shipment. In all cases, the Supplier is to maintain certifications as Quality Records at its facility in accordance with P0-3, "Supplier Quality System Requirements." Any of the following phrases, or a similar phrase with the same intent, may be used to indicate that certifications must be supplied with shipments:

- A. Certification Required
- B. Certs. Required
- C. Certified Reports Shall Be Provided with Shipment



3.1.1 Fabricated Parts,  
Certifications shall be sent with shipments when indicated by any of the following:

- A. Purchase Order
- B. Drawing

3.1.2 Assemblies and Processes

Certifications shall be sent with shipments when indicated by any of the following:

- A. Purchase Order
- B. Drawing
- C. Purchasing Specification

3.1.3 Raw-Material Suppliers and Distributors

All raw-material certifications will be shipped with the material.

3.1.4 Electrical Components

All electrical components will be shipped with certifications.

### **3.2 Requirements on All Certifications**

The following information must be provided with all certifications:

- A. CPI Purchase Order Number
- B. CPI Part Number/Specification Number and Revision Letter
- C. Quantity or Amount in Shipment
- D. Manufacture Lot, Heat, and/or Batch Number
- E. Compliance Statement
- F. Signature, Title of Company Representative, and Date

### **3.3 Certification Types**

The following information must also accompany these specific products or processes:

3.4.1 Age-Dated/Environmentally Controlled Material

- A. Material Description and Type
- B. Storage Conditions

**NOTE**

Specific storage conditions other than normal ambient and environment  
must be stated on the exterior of the package.

- C. Expiration Date (must also appear on each container of the product itself)

- 3.4.2 Ceramics
  - A. Material Description
  - B. Method of Manufacture (i.e., isostatic, extruded, etc.)
- 3.4.3 Raw Material (When required by CPI Purchasing Specification)
  - A. CPI Material Purchasing Specifications (i.e., P3-1B, P1-7D, etc.)
  - B. Size and/or Shape of Material
  - C. Test Reports (chemical and physical)
- 3.4.4 Special Processing (Typical processing certifications include plating, priming, heat-treating, ceramic metallizing, brazing, welding, etc.)
  - A. Total Quantity Processed
  - B. Definition of Process (CPI specification, MIL specification, or other brief description)
- 3.4.5 Specific Requirements or Tests (Mechanical, Electrical, Environmental)  
Description of the specific item being certified
  - A. CPI Drawing and Note Number
  - B. Applicable Specification and Requirement

## **4.0 PACKAGING AND LABELING**

### **4.1 Parts Protection in Packing**

Parts shall be packaged for shipment so they are protected from damage and contamination, prevented from nesting and entangling, and easy to unpack. Step 4.1.2B lists several packaging schemes that can be used as an aid. For more detail on packaging items, see Section 1 of M7-35, "Inventory packaging."

- 4.1.1 Unacceptable Packing Materials
  - Dusty and linty materials such as sawdust, shredded newspaper, and excelsior.
  - No use of tape on parts smaller than 2.0 square inches or diameter.
- 4.1.2 Suitable Packing Materials
  - A. Cellulose wadding (Kimpack), corrugated paper board, and expanded plastics (specific notes on drawings concerning packing requirements take precedence.)

B. Table 1 lists the recommended packaging schemes for several commodities:

**TABLE 1. Packaging by Commodity**

<b>Commodity</b>	<b>Recommended Packaging</b>
Ceramics	Individually package; bubble wrap
Braze Wafers/Washers	Poly bag; then lay flat in container (see P18-2 for packaging clean parts)
Bellows	Individually package; divider trays; Rondo boards
Small Drift Tubes and TWT Anodes	Cavity tray VMC-35, purchased from Odyssey (408) 260-4012 Individually wrap; poly bag
Large Drift Tubes (MPP)	Use plastic end caps to protect the nose
Diaphragms	Divider trays; individually wrap; poly bag (one piece per bag)
CONFLAT® Flanges	Individually wrap in bubble wrap, end cap on knife-edge side
Coupled-Cavity Pole Pieces and Cavity Plates	Divider trays P99056, F19951, F19952; poly bag (one piece per bag)
Polished Parts (parts having an exposed surface with a 16 finish or better)	Individually wrap in lint-free paper, then place in a bubble bag
Machined Parts less than 2 inches square or diameter	Individually wrap (no tape) and place in poly bag, bubble wrap, divider trays

4.1.3 Clean Parts Packaging

Refer to CPI specification P18-2, "Clean Packaging of Supplier-Provided Parts," for clean parts packaging requirements.

4.1.4 Properly Packed Materials

Pack large shipments and heavy parts in small lots for easier handling. Shipments packaged in a single corrugated carton shall not exceed 40 pounds.

**4.2 Transportation**

Corporate Freight Rates

Suppliers are encouraged to take advantage of CPI's corporate freight rates. Consult Purchasing for current carrier names and account numbers.

### **4.3 Package Labeling**

#### **4.3.1 Label Requirements**

Label each package as follows:

- A. Name of Supplier
- B. CPI Division Purchase Order Number
- C. Receiving Area
- D. CPI Division Part Number and Revision Letter
- E. Quantity (use same unit of measure as stated on purchase order)
- F. Other applicable information (i.e., Just-in-Time Delivery labels, EPA requirements, clean parts labels, etc.)

#### **4.3.2 Multiple Container Lots**

Lots shipped in more than one container must be sequentially labeled (i.e., Box 1 of 3, Box 2 of 3, etc.)

#### **4.3.3 Consolidated Shipments**

A consolidated shipment of multiple items and purchase orders is acceptable, provided that the shipping container is clearly marked as a consolidated shipment (see example below). Packing lists for individual purchase orders should always be placed on the outside surface of the consolidated shipping container.

Sample marking:

<p><b>CONSOLIDATED SHIPMENT</b> See packing lists in container for individual purchase orders.</p>
--

#### **4.3.4 Additional Labeling Requirements**

Labels shall meet all Federal and State labeling requirements, including those established by the EPA in 40 CFR, Part 82, "Protection of Stratospheric Ozone."

### **4.4 Packaging and Labeling of Beryllium Containing Parts and Materials**

- 4.4.1 Beryllium containing parts and materials (Beryllium metal, beryllium-copper, beryllium oxide ceramic) must be packed and labeled as required per CPI specification P18-2, "Clean Packaging of Supplier-Provided Parts."

## **5.0 GEOMETRIC DIMENSIONING AND TOLERANCING SYSTEM**

Interpret dimensions and tolerances according to the latest revision of ANSI Y14.5, "Dimensions and Tolerancing."

### **5.1 Unspecified Tolerance**

When the tolerance limit is not specified on the drawing or sketch, the following shall apply:

Decimal:	1 place $\pm 0.1$
	2 places $\pm 0.02$
	3 places $\pm 0.005$
	4 places $\pm 0.0005$
Fraction:	$\pm 1/64$
Angles:	$\pm 1^\circ$

### **5.2 Unspecified Finish**

The finish requirement for machined surfaces shall be 125  $\sqrt{\text{ }}$  unless otherwise specified.

Flaws are not included in surface finish measurements. The following flaws are not acceptable unless otherwise specified:

- Splits, tears, and cracks
- Displaced metal, folds (ironed-in or smeared-over scratches and burrs)
- Inclusions (imbedded particles—chips, burrs, foreign matter)
- Oxide (rust or corrosion)
- Seams

The surface finish must not exceed the average value of microinches shown by the symbol ( $\sqrt{\text{ }}$ ).

Unless otherwise specified, the general finish in the title block applies only to machined surfaces.

Commercial stock surface finish is acceptable when "stock" is specified as a dimension.

### **5.3 Unspecified Flatness**

When flatness is not specified, it shall not exceed the values in Table 2 and shall not violate the MMC perfect-form boundary.

**TABLE 2: Flatness Tolerance**

Surface Finish Required	Unit Variation in any Direction	Total Variation if Length is 1" or More
63 ✓ or better	0.003 in. per in.	0.003 times the longest element of the feature with a maximum of 0.012
64 ✓ or rougher	0.005 in. per in.	0.005 times the longest element of the feature with a maximum of 0.020

**5.4 Unspecified Cylindricity**

When cylindricity is not specified on the drawing, diameters shall be cylindrical within one-half the feature size tolerance and shall not violate the MMC perfect-form boundary.

**5.5 Unspecified Perpendicularity**

When implied right (90°) angles are not specified in the drawing, they shall be within ±0° 15' of the intended 90° angle or 0.004 inch per inch maximum error and shall not violate the MMC perfect-form boundary.

**5.6 Unspecified Parallelism**

When surfaces shown in parallel relationship are not specified on the drawing, they shall be parallel within 0.002 inch per inch of width or length and shall not violate the MMC perfect-form boundary.

**5.7 Unspecified Concentricity**

When concentricity is not specified on the drawing, the concentricity of any two round features shown on the same centerline shall be equal to one-half the arithmetic sum of the feature size tolerances. The feature having the smallest total tolerance shall be considered datum if no datum is specified.

Example: The concentricity between D1 and D2 will be:

Tolerance D1 = ±0.002 = 0.004 THIS IS DATUM (smallest total tolerance)

D2 = ±0.005 = 0.010

Axis of D2 must be concentric to axis of D1 by 0.007 or less.

$$[(0.004 + 0.010)/2 = 0.014/2 = 0.007]$$

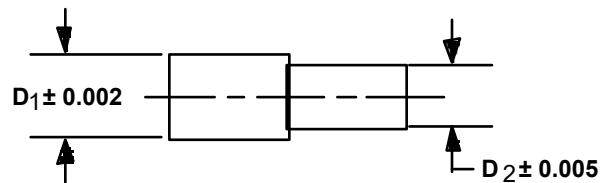

D4010  
 F M7-13

**FIGURE 4: Unspecified Concentricity**

### 5.8 Unspecified Position

When positional symmetry is not specified, ( $\oplus$  formerly  $\equiv$ ) features shown as lying on the centerline of a part (i.e., a slot in a screw head) shall be symmetrical within the total width tolerance of the feature.

### 5.9 Unspecified Circularity

Diameters that do not have a specified roundness tolerance shall be round within one-half the feature size tolerance but must not extend beyond the MMC perfect-form boundary.

### 5.10 Unspecified Countersinks

Unless otherwise specified, all countersinks shall be  $82^\circ \pm 5^\circ$ .

## 6.0 TOOLING

Parts contamination can result from contact with some materials commonly used for tooling. Tooling made of brass, bronze, or platinum shall not be used. Cadmium- or zinc-plated tooling shall not be used.

**Exception:** Parts that are not used inside the vacuum envelope of microwave, power-grid, and X-ray VEDs (or similar devices) are exempt from this requirement. These parts are either made from brass, aluminum, zinc, lead, and plastic or designated by the drawing as not used in the vacuum envelope of the VED.

## 7.0 CLEANING, PLATING, AND COATING OF SURFACES

All fabricated parts must be received at CPI free of machining lubricants, oils, contaminants, and particles. (The exception to this rule shall be components made from materials that would rust if not protected by an approved rust inhibitor. Materials in this category shall be degreased and coated with an approved rust inhibitor before being packaged for shipment or introduced into the Supplier's stock).

Plating, coating, or other metal finishing to be performed by Suppliers shall be specified on the drawing using military or industry standards. All quality-assurance provisions in the standard shall apply. Processes to be performed within CPI shall refer to the CPI specification.

When a part or assembly drawing specifies plating or coating, dimensions on the drawing are the machined/fabricated dimensions. The part or assembly has been designed to allow for the application of the plating or coating as specified. Any dimensions that apply after plating will be noted separately.

Specified coating thicknesses are the average thickness for the entire part. Normal thickness distribution based on current density is assumed. For example, areas of high-current density, such as sharp edges and outer ends of parts, can have considerably more than the specified coating thickness. Areas of critical thickness will be noted on the drawing. Compliance to critical thickness specifications must be verified and documented.

All threaded holes shall be masked prior to plating or painting to ensure there is no buildup of the plating or paint in the threaded hole.

## 8.0 BURRS

Burrs adversely affect VED performance by acting as traps for chemical cleaning solutions, serving as “virtual” leaks and as point emission sources in areas of high-electrical potential.

### 8.1 Definition

A burr is found at the edge of a stamped or machined feature and is defined as a small projection of material that interrupts the normal contour of the plane or surface. (Note that this definition says a burr can only occur at an edge of a feature; anything on the surface is a nodule or particle, etc.)

### 8.2 Types

Various types of burrs are defined as follows:

- An imbedded burr is any burr that has been pressed into the material.
- A feather burr is a very fine or thin burr generally less than 0.001-inch thick.
- A hanging burr is a burr that is not firmly attached to the workpiece.
- A rolled-over burr is a tight burr that is curled over on itself in such a manner that it traps contaminants within itself.

**NOTE:** ROLLED-OVER AND IMBEDDED BURRS ARE NOT ALLOWED. EMBEDDED PARTICLES ARE NOT ALLOWED.

### 8.3 Height

Hanging burrs and feather burrs are subject to the limits prescribed below.

Burr height is defined as the maximum distance the burr projects above the surface of the workpiece.

**TABLE 3. Burr Heights**

<b>Maximum Burr Heights Allowed for Machined Features</b>		
$32\sqrt{\phantom{x}}$ Finish or Better	$63\sqrt{\phantom{x}}$ Finish	$125\sqrt{\phantom{x}}$ Finish or Worse
0.0005	0.002	0.003

In addition to burr height, burr direction may be a critical factor for sheet-metal parts. If so, the burr direction will be called out on the drawing (see Section 10.12).

Maximum burr heights for sheet-metal parts will be found in Section 10.11.

### 8.4 Removal

It shall be standard practice to remove burrs from the edges of all surfaces, even if this requirement is not noted on the drawing, such that the requirements stated in Section 8.2 and Section 8.3 are satisfied.

The notation “No Burrs” appearing on a drawing specifies that burrs be removed to the extent that they are not visible under 10X magnification.

While deburring, it is imperative that excessive material is not removed; after deburring, the parts must still be within the dimensional tolerances specified on the print.



The deburring method used must not introduce any contamination, and all loose particles must be removed.

Contamination resulting from embedded particles introduced during the deburring processes can adversely affect the performance of our product. The use of bonded abrasives (i.e., a Cratex stick) that can leave embedded particles is **NOT** acceptable.

### 8.5 Edges

An edge is defined as the intersection of two planes of base material at an angle greater than  $180^\circ$  (outside).

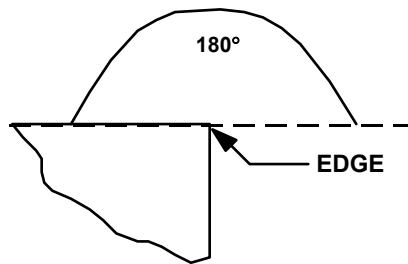

D4019

**FIGURE 5: Edges**

It shall be standard practice to remove all sharp edges unless otherwise specified.

Edges shall be broken by either a  $45^\circ$  chamfer or a radius. If limits are not specified on the drawing, a 0.005-inch maximum chamfer or radius is acceptable for lengths less than 1 inch. For features greater than 1 inch, a 0.010-inch maximum chamfer or radius is acceptable.

A “sharp edge” callout on a drawing shall be interpreted as being limited to a 0.002-inch maximum chamfer or radius.

### 8.6 Corners

A corner shall be defined as the intersection of two or more planes of base material at an angle less than  $180^\circ$  (inside).

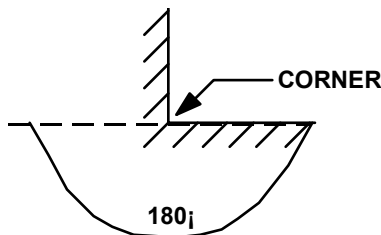

D4020

**FIGURE 6: Corners**

Unless otherwise specified on the drawing, all corners shall be limited to a 0.010-inch maximum radius.

A “sharp corner” callout on a drawing shall be interpreted as being a corner with no greater than a 0.002-inch maximum radius.

Undercuts shall be subject to rejection unless otherwise specified on the drawing.

**8.7 Sheet Metal**

For additional requirements concerning burrs on sheet-metal products, see Section 10.11.

**9.0 THREADS**

All threads, unless otherwise specified on the drawing, shall conform to the unified tabulations and formulations of FED-STD-H28, "Screw Thread Standards for Federal Services." Unified form threads, American National Form threads, special threads, and unified miniature screw threads shall be defined by the unified system.

**9.1 Internal Threads**

All internal threads shall be tapped using standard machine screw taps or machined. **THREAD-FORMING TOOLS ARE PROHIBITED UNLESS OTHERWISE SPECIFIED** as formed threads can trap contaminants. **EXCEPTION:** Parts that are not used inside the vacuum envelope of vacuum-electron devices are exempt from this requirement. These parts are either made from brass, aluminum, zinc, lead, or plastic or are designated by the drawing as not used in the vacuum envelope of the VED.

**9.2 Threaded Holes**

All threaded holes shall be countersunk  $82^\circ \pm 5^\circ$  to a diameter equal to at least the major diameter of the specified thread. In the case of through-holes, this requirement shall apply to both ends. The countersink diameter shall not exceed 0.020 inch over the major thread diameter.

The specified depth of a threaded hole shall mean there shall be full threads to that depth.

Where a three-place decimal dimension ( $\pm 0.005$  tolerance) is used to define thread depth, one full thread shall be allowed beyond the dimension.

The depth of the tap drill shall not be specified unless critical. If the depth of a tap/twist drill hole is not specified, the depth of the hole shall not exceed the full thread depth plus a dimensional allowance equal to the nominal thread diameter.

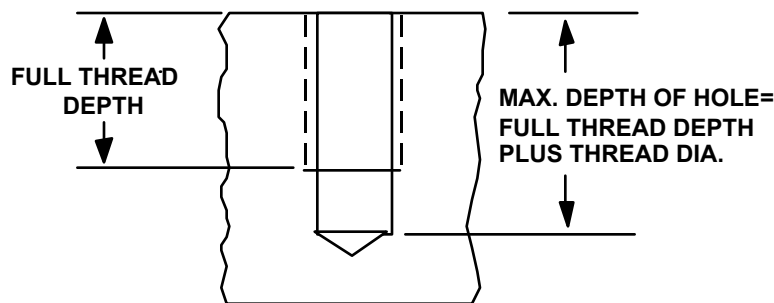

**FIGURE 7: Thread Depth**

In gauging a threaded hole, the "No-Go" gauge shall not penetrate more than three turns. Exceptionally short thread length (less than three pitches) may pass over the plug gauge provided there is a perceptible drag. The "Go" gauge shall freely penetrate the full length of the thread.

**9.3 Threaded Parts**

The end of all external threads shall be chamfered at  $45^\circ \pm 5^\circ$  to the minor diameter.

**9.4 Full-Form Threads**

The length of fully formed threads is dimensioned. When only one dimension is used to specify the length of threads, it is interpreted to mean the length of fully formed threads, excluding runout. Where a chamfer, not exceeding two pitches in length, exists at the entering end of the thread, it is included in the length of fully formed threads. Figure 5 below shows methods of delineating with no limit on runout.

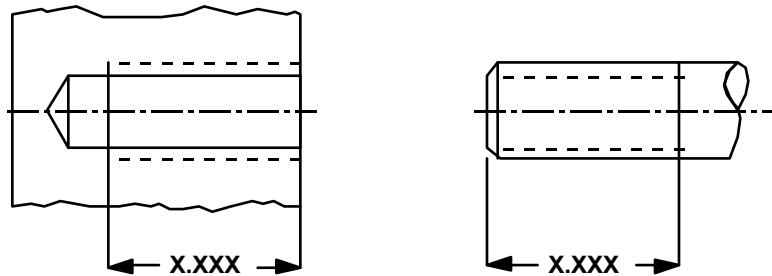

D4025

**FIGURE 8: Thread Length**

**9.5 Unspecified Thread Class of Fit**

**TABLE 4: Thread Class**

Thread Description	Thread Class of Fit
External Threads	2A
Internal Threads	2B
External Threads (Metric)	6G
Internal Threads (Metric)	6H
Threaded Inserts (#3-#8)	2B
Threaded Inserts (>#8)	2B or 3B

**10.0 SHEET-METAL PRODUCTS FABRICATION REQUIREMENTS**

**10.1 Sheet Metal**

Sheet metal is considered to be sheet stock that has a nominal thickness of 0.250 (1/4) inch or less.

**10.2 Features and Surfaces**

Features and surfaces of sheet-metal parts shall be within drawing dimensional limits of size in the unrestrained condition unless otherwise specified.

**10.3 Machined Features**

Obvious machined features such as countersinks, chamfers, screw threads, and close-tolerance (0.003 inch or less) holes shall conform to the body of this standard.

**10.4 Circular Runout**

The circular runout of any internal or external diameter shall not exceed the value specified in Table 5 with respect to any other diameter on the same axis. If a datum axis is established by the drawing, the circular runout shall be in relation to that datum axis.

**TABLE 5: Circular Runout of Diameters**

<b>DIAMETER (Inches)</b>	<b>CIRCULAR RUNOUT TOLERANCE (Inches)</b>
Through 6.000	0.040
6.001 through 9.000	0.070
9.001 through 20.000	0.100
20.001 through 36.000	0.150
Over 36.000	0.200

**10.5 Washer-Type Punching**

The center hole of washer-type punchings shall be located within the position tolerance shown in Table 6 in relation to the outside diameter.

**TABLE 6: True Position of Washer-Type Punchings Relative to OD as Datum Feature**

<b>INSIDE DIAMETER (Inches)</b>	<b>POSITION TOLERANCE (MMC) (Inches)</b>
Through 6.000	0.030 dia.
6.001 through 12.000	0.060 dia.
12.001 through 24.000	0.100 dia.
Over 24.000	0.150 dia.

**10.6 Flatness**

Variations in surface flatness shall not exceed the values shown in Table 7 and Table 8 and shall not violate the dimensional limits of size.

**TABLE 7: Flatness for Nonwelded Surfaces**

<b>NOMINAL STOCK THICKNESS (Inches)</b>	<b>UNIT VARIATION IN ANY DIRECTION</b>
Through 0.090	0.010 in/in
0.091 through 0.250	0.007 in/in

**TABLE 8: Flatness for Welded/Brazed Surfaces**

<b>NOMINAL STOCK THICKNESS (Inches)</b>	<b>UNIT VARIATION IN ANY DIRECTION</b>
Through 0.032	0.025 in/in
0.033 through 0.060	0.020 in/in
0.061 through 0.125	0.015 in/in
0.126 through 0.250	0.005 in/in

**10.7 Parallelism and Perpendicularity**

The elements of flat sheet-metal surfaces that are shown as parallel or perpendicular shall be parallel or perpendicular to each other within 3°. The datum shall be the longest adjacent surface that is parallel or perpendicular to the surface being measured.

**10.8 Edges and Corners**

Sheared edges are permissible but they, and all other edges and corners, shall be broken in accordance with the illustration below. This applies only to finished parts and not to “in-process” pieces of a welded or brazed assembly.

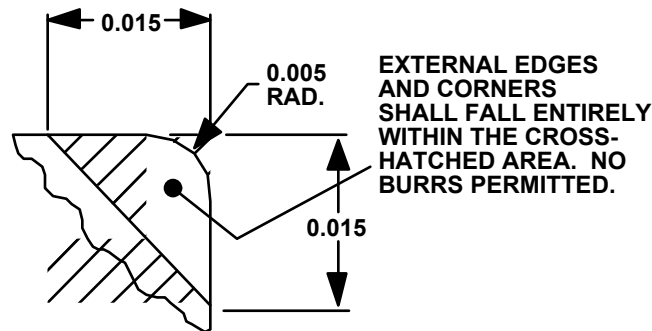

**FIGURE 9: Edges and Corners**

**10.9 Stock Thickness after Forming**

Sheet-metal thickness in all areas of formed parts may be reduced by a maximum of 25 percent of the nominal stock thickness. Local thickening due to the part shape and the forming process is acceptable up to 30 percent of the nominal stock thickness.

If material thickness is 0.025” or less, supplier must verify thickness in all areas, and pay particular attention to the formed feature(s). Verification methods can include mechanical measurement, CMM, cross-section (i.e., EDM cut, metallurgical section, milling), or ultrasonic.

**10.10 Breakaway**

The maximum breakaway of punched or sheared edges shall not be more than 20 percent of the stock thickness as shown below. The dimensional limits of size apply only to those portions of the edge where breakaway has not occurred.

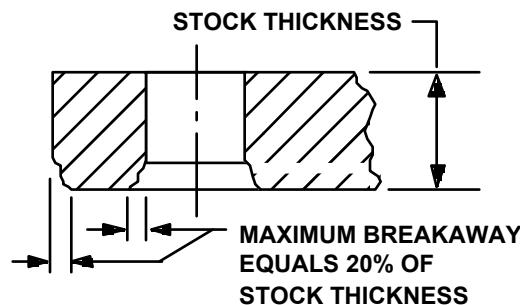

**FIGURE 10: Maximum Breakaway**

**10.11 Burrs**

The following burr specifications are in addition to those covered in Section 8:

Limitations — under the conditions specified below, maximum burr heights are as follows (also see illustration in Section 10.12):

**TABLE 9: Burr Height Allowance**

STOCK THICKNESS	MAX BURR HEIGHT ALLOWANCE
0.004 and under	0.001
over 0.004 to 0.014 incl.	0.0015
over 0.014 to 0.039 incl.	0.002
over 0.039 to 0.124 incl.	0.003
over 0.124 to 0.186 incl.	0.004
over 0.186 to 0.311 incl.	0.005
over 0.311	0.010

Wire and ribbon burrs on cut lengths of wire and ribbon, including flattening because of shearing pressure, shall not exceed 10 percent of the diameter or thickness unless otherwise specified.

**10.12 Burr Symbols and Drawing Callouts**

- A “B” symbol placed on extension lines indicates that burrs are acceptable.
- The maximum burr height allowed is shown adjacent to the symbol.
- Arrowheads may be used to indicate the side on which burrs may occur.
- Symbols placed on both sides indicate that burrs are acceptable on both sides.
- A radius may be specified on an edge to show the direction of punching.

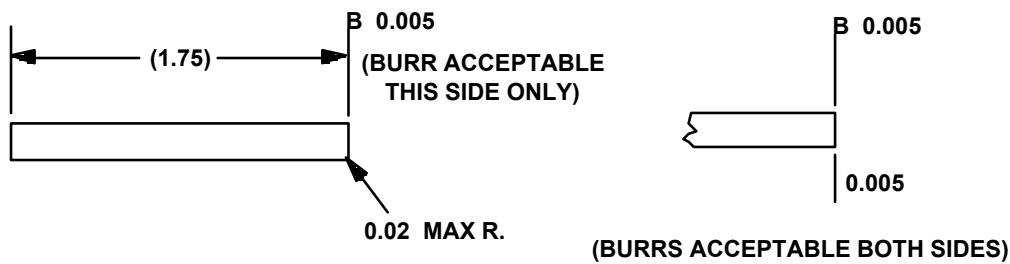

D4028  
 F M7-13

**FIGURE 11: Burr Symbols**

**11.0 CASTING AND FORGING REQUIREMENTS**

**11.1 Position**

The position of coaxial or coplanar cast or forged features shall be in accordance with Table 10 with respect to each other; it should be noted that the position does not include out-of-roundness. If a cast or forged datum axis is established by the drawing, the position control shall be in relation to that datum axis. The concentricity shall be  $\pm 0.010$ " at the lowest point on the surface of the forging before any surface-removal procedure (OFE Copper only).

**TABLE 10: Position of Coaxial/Coplanar Features**

	<b>Feature Dia/Width</b>	<b>Position Tol. RFS (S)</b>
Sand Casting	Up to 6.000	0.060
	6.001 to 12.000	0.090
	Over 12.000	0.120
Die Castings	Up to 6.000	0.020
	6.001 to 12.000	0.040
	Over 12.000	0.060
Shell, Plaster, Ceramic, Permanent Mold, or Investment Castings	Up to 6.000	0.040
	6.001 to 12.000	0.060
	Over 12.000	0.080
Forgings	Up to 6.000	0.060
	6.001 to 12.000	0.090
	Over 12.000	0.120

**11.2 Flatness**

Surface flatness shall not exceed the values specified in Table 11 except in the area of a parting line.

**TABLE 11: Flatness**

	<b>Surface Finish</b>	<b>FLATNESS TOLERANCE</b>	
		<b>Variation In Any Direction</b>	<b>Total Variation (Lengths of More Than 1 Inch)</b>
Castings	250 and Finer	0.015 in./in.	0.060 max
	251 Through 500	0.020 in./in.	0.080 max
Forgings	500 and Finer	0.010 in./in.	0.060 max
	500 and Over	0.020 in./in.	0.100 max

**11.3 Cleanup**

Gates, risers, flash, runners, and parting lines on surfaces not subject to subsequent machining shall be trimmed and blended smooth with the part contour. Surfaces subject to subsequent machining shall be finished according to normal industry practice.

**11.4 Mismatch**

Parting-line mismatch for forgings shall not exceed 0.05 inch maximum. Mismatch is defined as a defect resulting from die misalignment, producing an offset on the surfaces of the forging at the parting line. The mismatch of castings shall be contained within the applicable position requirements.

**11.5 Draft**

Draft shall be applied as additional material to the dimensions shown on the drawing and shall not exceed the limits specified in Table 12.

**TABLE 12: Draft Angle**

	<b>DRAFT ANGLE</b>	
	<b>Internal</b>	<b>External</b>
Sand, Shell Mold, and Ceramic Mold Castings	3° max	3° max
Plaster Mold Castings	3° max	1°30' max
Investment Castings	1°30' max	1°30' max
Permanent Mold and Semiperm Mold Castings	4° max	4° max
Forgings	10° max	8° max

**11.6 Repair**























Castings and forgings shall not be repaired by welding, plugging, impregnating, peening, or any other methods except as permitted by specific drawing notes. Castings that shall be subsequently welded or brazed shall not be impregnated. Surface conditioning using standard shop practice for removal of surface defects is permissible within drawing dimensional limits.











**12.0 EDM FABRICATION REQUIREMENTS**

For components fabricated using an EDM process (including wire EDM), parts will be delivered free of any contaminants from the dielectric fluid and electrode material. If transfer of material from the electrode is unavoidable, the supplier is responsible for subsequent cleaning to remove the deposit or for using a non-contaminating electrode such as tungsten.



## APPENDIX: GEOMETRIC SYMBOLOGY

SYMBOL	MEANS	ASME Y14.5-2018 REFERENCE
	Datum Symbol	Fig. C-6
	Datum Symbol – older drawings	-----
	Datum Target	Fig. C-7
	Basic Dimension	Fig. C-6
	Diameter	Fig. C-6
$s\phi$	Spherical Diameter	---
( )	Reference	Fig. C-6
	Feature Control Frame	Fig. C-7
	Least Material Condition (LMC)	Fig. C-6
	Regardless of Feature Size (RFS) – older drawings	-----
	Maximum Material Condition (MMC)	Fig. C-6
	Projected Tolerance Zone	Fig. C-6
<b>R</b>	Radius	Fig. C-7
SR	Spherical Radius	Fig. C-7
	Arc Length	Fig. C-7
	Chain Line	---
	Flatness	Fig. C-6
	Flatness on Older Prints	---
	Straightness	Fig. C-6
	Circularity (Roundness)	Fig. C-6
	Cylindricity	Fig. C-6
	Perpendicularity	Fig. C-6
	Angularity	Fig. C-6
	Parallelism	Fig. C-6
	Profile of a Line	Fig. C-6
	Profile of a Surface	Fig. C-6

	Circular Runout	Fig. C-6
	Total Runout	Fig. C-6
	Concentricity and Coaxiality – older drawings	-----
	Position	Fig. C-6
	Symmetry – older drawings	-----
	Counterbore	Fig. C-7
	Spotface	Fig. C-7
	Countersink	Fig. C-7
	Depth	Fig. C-7
	Repetitive Features and Dimensions	---